

URGENT SAFETY RECALL NOTICE

STOP USE AND RETURN FOR INSPECTION AND UPGRADE

Notice Date: October 21, 2019

Manufacturer: C3 Manufacturing

Affected Product: Perfect Descent™ Auto Belay model 220 Indoor, Outdoor, Speed Drive, and Direct Drive units manufactured from February 2017 through April 2019

C3 Manufacturing is announcing a stop use and recall of auto belay units that may contain a material defect that can prohibit the lanyard from retracting. While no accidents have been reported, C3 is voluntarily recalling affected units out of an abundance of caution and consistent with our focus on safety and quality. Our investigation indicates that defects may be present in the material used to manufacture the retraction spring which can result in partial or complete fracture of the spring and loss of retraction force. Complete fracture of the retraction spring will cause the lanyard to stop retracting and, in some cases, the lanyard may “pay out” thereby creating additional slack in the system. Climbing while tethered to a unit with a fractured retraction spring may result in serious injury or death.

C3 Manufacturing requests that you immediately remove all affected auto belays from service and return them to your nearest service center for warranty upgrade of the retraction spring.

All returned units will be upgraded to the new Duplex Spring Design featuring twin retraction springs. This new system comprised of two independent retraction springs will permit the unit to operate in the event of a spring failure. The daily inspection procedure provides a simple method for confirming the dual spring operation.

This notice affects units that are within the following serial number ranges:
I-0970 through I-3109 manufactured February 2017 through November 2018
S-0604 through S-1609 manufactured March 2017 through December 2018
S-1695 through S-1762 manufactured February 2019 through March 2019
D-1015 through D-1385 manufactured June 2018 through December 2018
D-1710 through D-1722 manufactured March 2019
D-1726 through D-1751 manufactured March 2019 through April 2019
D-1761 through D-1777 manufactured April 2019

STOP USE OF AUTO BELAY AND IMMEDIATELY TAKE THE FOLLOWING ACTION

1. Locate Perfect Descent Serial Number. Use the diagrams on page two (2) of this notice to find the serial numbers and date of manufacture on your device. If your auto belay falls within the ranges noted above, immediately remove from use and follow the instructions below. No action is required for units with a serial number outside the range listed in this notice.

Note: If factory service has been performed to a unit in 2019, Please contact your service center for more information as it may have already been upgraded to the Duplex Spring System.

2. Contact C3 Manufacturing or the nearest Authorized Service Center to arrange the return of the affected devices. Contact C3 Manufacturing at 303-953-0874 or service@perfectdescent.com to make arrangements for the return and repair of affected Perfect Descent auto belays. Customers outside of the USA may contact the nearest Perfect Descent Authorized Service Center directly. A list of Perfect Descent

Authorized Service Centers can be found at <https://www.perfectdescent.com/service-centers/>. Complete the Inspection and Upgrade Form included with this notice and return a copy with each unit shipped to a service center.

3. Choose your option for the Duplex Spring upgrade

Option 1: Warranty Upgrade of Retraction Spring Only

The Service Center will upgrade the device to the Duplex Spring Design and perform an inspection of the internal components during the upgrade process. The unit will not be recertified and will need to be returned for mandatory recertification on or before the next service date as indicated on the device labeling. There will be no charge for the spring upgrade, unit inspection, and return transportation fees. Return shipping will be by the most economical method available and can be expedited for an additional charge.

Option 2: Bi-Annual Recertification Plus Warranty Upgrade of Retraction Spring

The Service Center will perform the bi-annual recertification **AND** upgrade the device to the Duplex Spring Design in the process. The recertification fee will be prorated based on the number of months left in the service cycle and the Duplex Spring Design upgrade will be included at no additional charge. Proration only applies to the base recertification fee and does not include return shipping or replacement components that may be in addition to the base service fee (ie replacement lanyard). Recertified units will begin a new 24-month service cycle upon return.

We understand that auto belays are an important part of your business and we apologize for any disruption this action may cause. We will make every attempt to upgrade and return your device(s) as quickly as possible.

**Note-Devices outside the range indicated in this notice will be upgraded to the Duplex Design spring system upon the next recertification. Additional charges may apply at that time. Contact an Authorized Service Center for details.*

Use these diagrams to locate your serial number and date of manufacture.

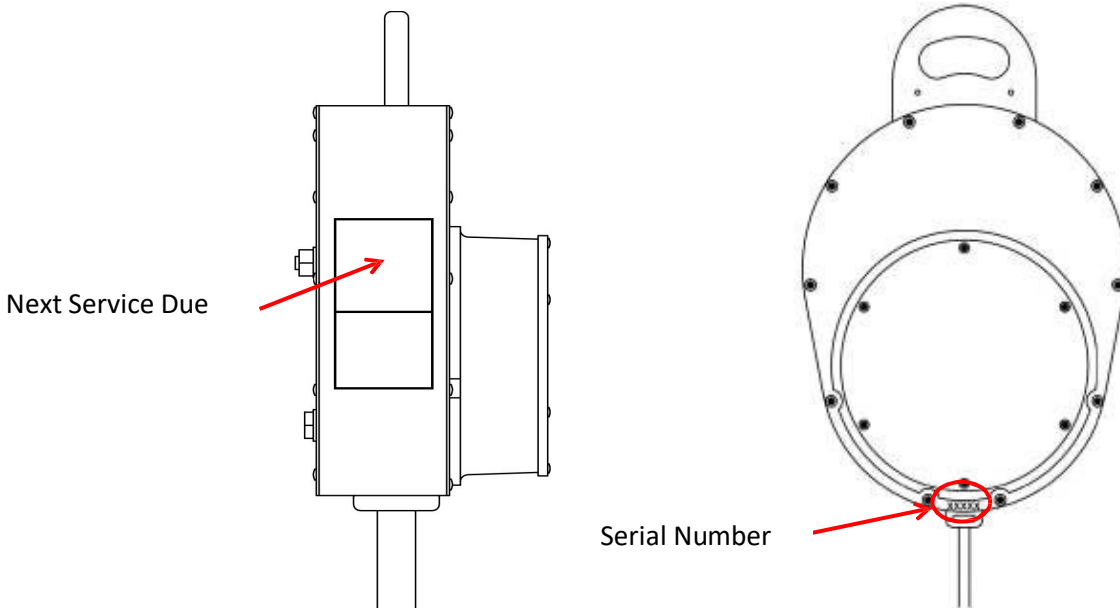

Contact Name
Company Name
Return address
City
State
Postal code
Email
Phone
Notes

Perfect Descent Inspection and Upgrade Form

Choose one option below.

Please perform the full recertification on my device. This will reset the Next Service Due date. I understand that the standard service charge will be prorated based on the number of months remaining on my current service cycle. I understand that if I do not have credit terms with the Authorized Service Center, I must contact the Service center to make payment arrangements.

Replace lanyard if necessary (additional charge will apply).

Do Not replace lanyard. Customer understands that Customer is responsible for lanyard condition and proper replacement when necessary.

Signature _____ Date _____

I do not wish to have the full recertification performed at this time. I understand that I must return the device to an Authorized Service Center on or before the Next Service Due Date that is currently specified on my device. Lanyard will not be replaced. Customer understands that Customer is responsible for lanyard condition and proper replacement when necessary upon return.

Signature _____ Date _____

Please include this sheet with your device and return to your nearest Factory Authorized Service center.